

ABB AUTOMATION

The Company

ABB Automation is an established world force in the design and manufacture of instrumentation for industrial process control, flow measurement, gas and liquid analysis and environmental applications.

As a part of ABB, a world leader in process automation technology, we offer customers application expertise, service and support worldwide.

We are committed to teamwork, high quality manufacturing, advanced technology and unrivalled service and support.

The quality, accuracy and performance of the Company's products result from over 100 years experience, combined with a continuous program of innovative design and development to incorporate the latest technology.

The NAMAS Calibration Laboratory No. 0255 is just one of the ten flow calibration plants operated by the Company, and is indicative of ABB Automation's dedication to quality and accuracy.

BS EN ISO 9001



St Neots, U.K. – Cert. No. Q5907
Stonehouse, U.K. – Cert. No. FM 21106

EN 29001 (ISO 9001)



Lenno, Italy – Cert. No. 9/90A



Stonehouse, U.K.

Use of Instructions



Warning.

An instruction that draws attention to the risk of injury or death.



Caution.

An instruction that draws attention to the risk of damage to the product, process or surroundings.



Note.

Clarification of an instruction or additional information.



Information.

Further reference for more detailed information or technical details.

Although **Warning** hazards are related to personal injury, and **Caution** hazards are associated with equipment or property damage, it must be understood that operation of damaged equipment could, under certain operational conditions, result in degraded process system performance leading to personal injury or death. Therefore, comply fully with all **Warning** and **Caution** notices.

Information in this manual is intended only to assist our customers in the efficient operation of our equipment. Use of this manual for any other purpose is specifically prohibited and its contents are not to be reproduced in full or part without prior approval of Marketing Communications Department, ABB Automation.

Health and Safety

To ensure that our products are safe and without risk to health, the following points must be noted:

1. The relevant sections of these instructions must be read carefully before proceeding.
2. Warning labels on containers and packages must be observed.
3. Installation, operation, maintenance and servicing must only be carried out by suitably trained personnel and in accordance with the information given.
4. Normal safety precautions must be taken to avoid the possibility of an accident occurring when operating in conditions of high pressure and/or temperature.
5. Chemicals must be stored away from heat, protected from temperature extremes and powders kept dry. Normal safe handling procedures must be used.
6. When disposing of chemicals ensure that no two chemicals are mixed.

Safety advice concerning the use of the equipment described in this manual or any relevant hazard data sheets (where applicable) may be obtained from the Company address on the back cover, together with servicing and spares information.

CONTENTS

Section	Page
1 INTRODUCTION	1
2 SETTING UP	2
2.1 Instrument Power-up – Fig. 2.1 and 2.2	2
2.1.1 Power-up Error Codes	3
2.2 Fitting the Chart – Fig. 2.4	4
2.3 Fitting the Pen Capsule(s) – Fig. 2.5	4
3 DISPLAYS & CONTROLS	5
3.1 Displays and L.E.D. Indicators – Fig. 3.1	5
3.2 Use of Controls – Fig. 3.2(a) to (f)	6
4 OPERATION	7
4.1 Input Error Messages – Fig. 4.2	8
4.2 Operating Page Displays	9
4.3 Alarm Acknowledge Page	10
4.3.1 Alarm Indications – Fig. 4.3	10
4.3.2 Acknowledging Alarms	10
4.3.3 Using the Alarm Acknowledge Page	10
4.4 Totals Page Displays	11
4.5 Access to Configuration Levels	12
5 SIMPLE FAULT FINDING	13
6 SPARES LIST	13

1 INTRODUCTION

The COMMANDER 1900 series of documentation is shown in Fig. 1.1. The **Standard Manuals**, including the specification sheet, are supplied with all instruments. The **Supplementary Manuals** supplied depend on the specification of the instrument.

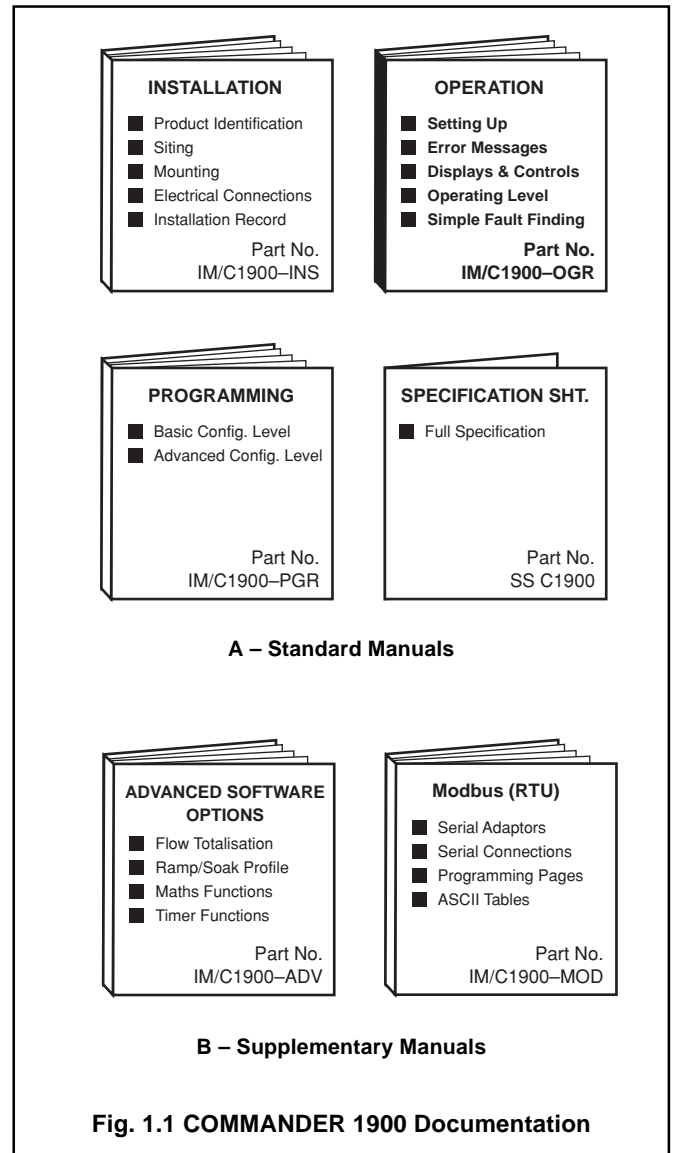

Fig. 1.1 COMMANDER 1900 Documentation

2 SETTING UP

2.1 Instrument Power-up – Fig. 2.1 and 2.2

Caution. Ensure that all connections, especially to the earth stud, are made correctly.

- Check that the input sensors are installed correctly.
- Check that the pen(s) are installed correctly – see Fig. 2.1.
- Switch on the supply to the instrument, any power-operated control circuits and the input signals. Wait for the pens to settle.

Note. On power-up, the pens are moved to an off-chart position for automatic referencing. Pen chatter may occur on those pens nearest the reference position. **This is a normal function of the instrument.**

- The start-up sequence shown in Fig. 2.2 is displayed on faceplate 1 when the supply is first switched on.

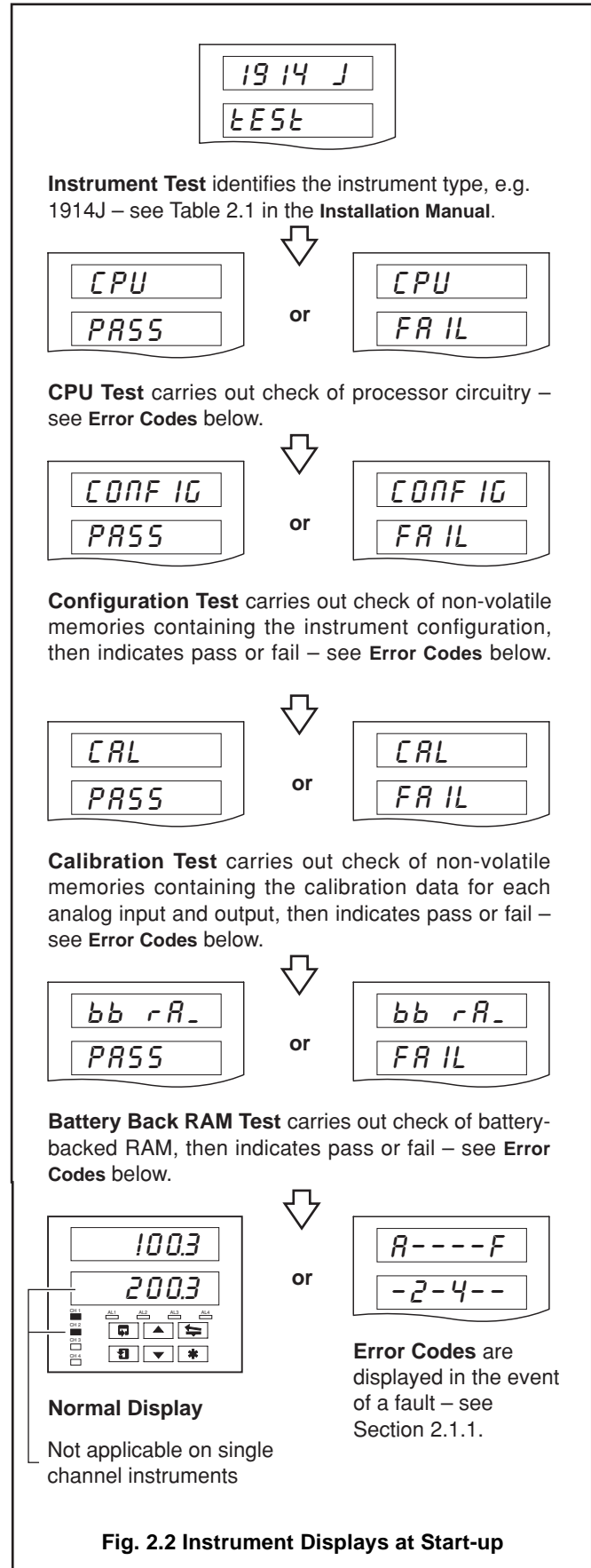
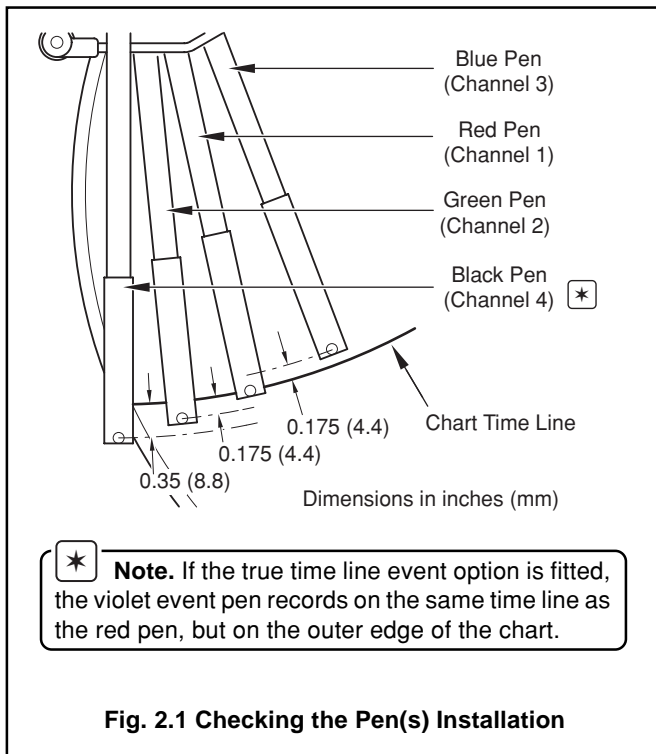

2.1.1 Power-up Error Codes

If any of the power-up tests fail (see Fig. 2.2), error codes are displayed to identify the fault. Refer to Fig. 2.3 for error code interpretations.

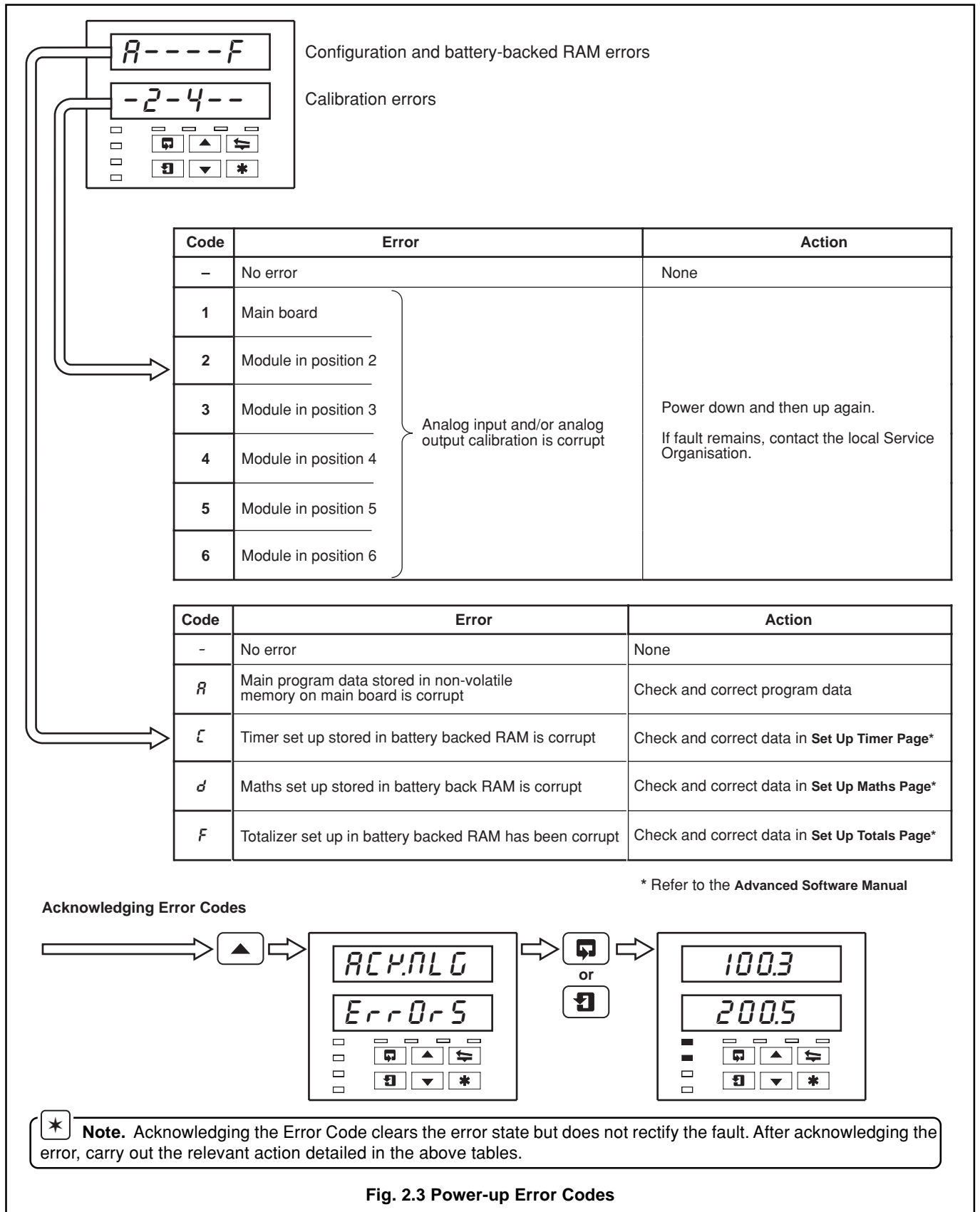

2.2 Fitting the Chart – Fig. 2.4

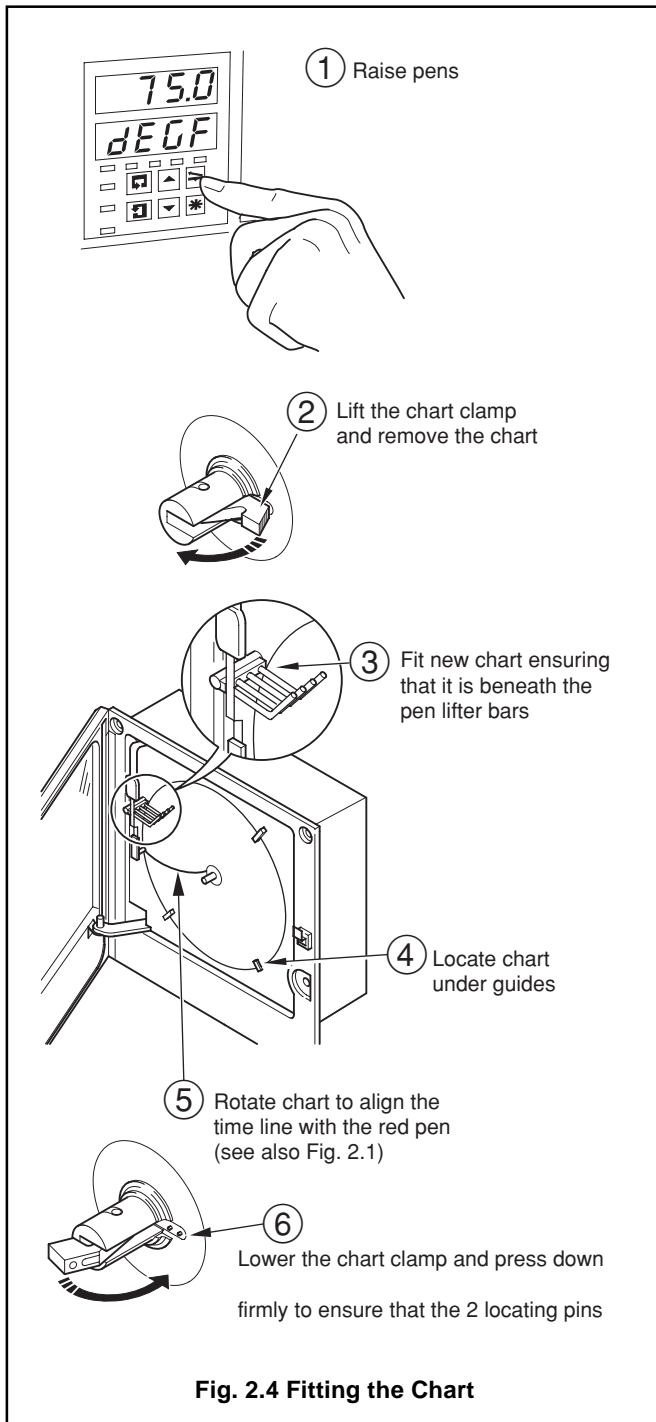

2.3 Fitting the Pen Capsule(s) – Fig. 2.5

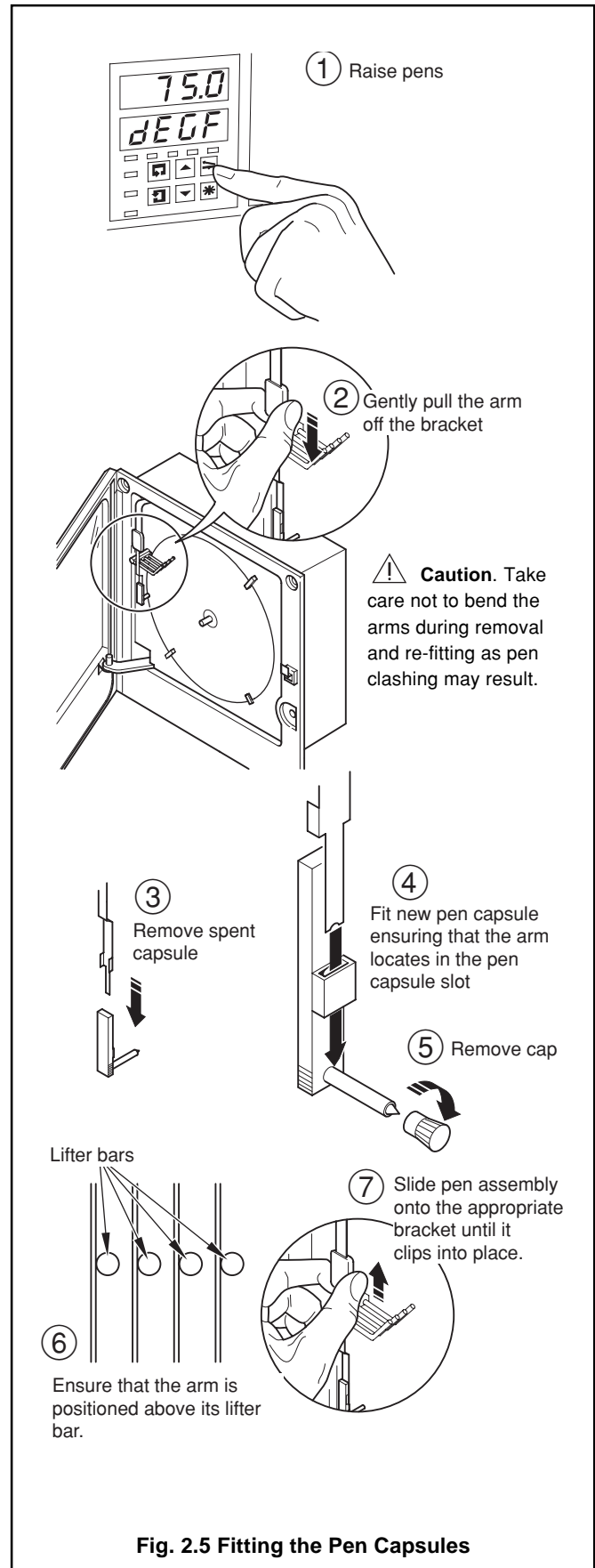

The displays, i.e.d. indicators and operation/programming controls are located on the faceplate on the front panel of the instrument – see Fig 3.1.

3.1 Displays and L.E.D. Indicators – Fig. 3.1

The displays comprise 2 rows of 6 characters.

At the top of each programming page (the page header) both displays are used to describe the particular page selected.

When parameters within the selected page are viewed the upper display shows the parameter and the lower display shows the value or setting for that parameter.

Alarm and Channel states are indicated by separate i.e.d.s on the faceplate of the front panel of the instrument – see Sections 4.1, 4.2 and 4.3.

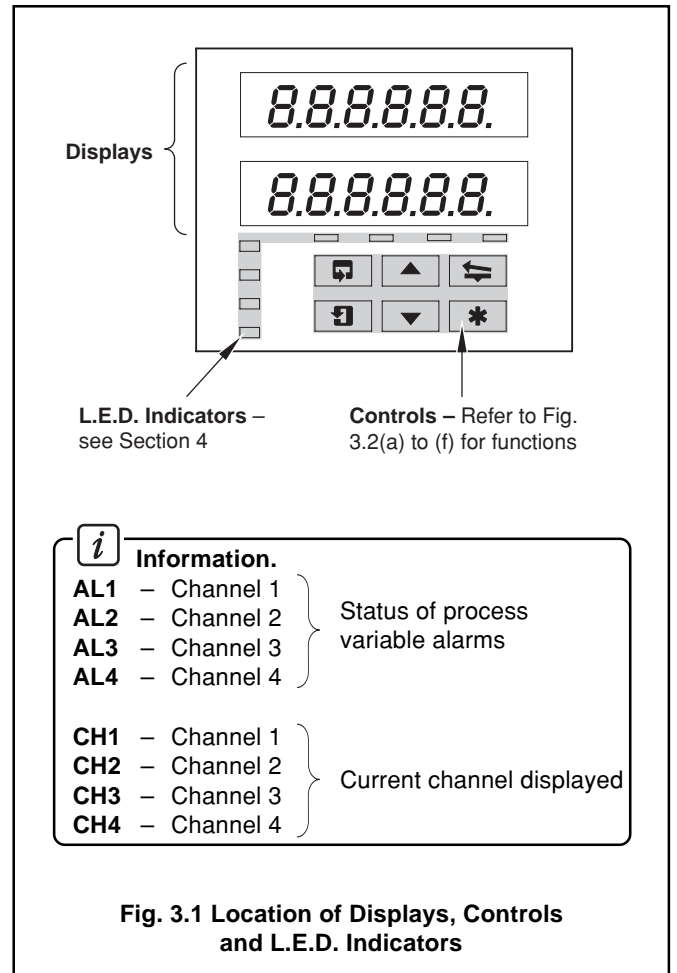

A	<i>A</i>	L	<i>L</i>
B	<i>b</i>	M	<i>-</i>
C	<i>C</i> or <i>c</i>	N	<i>n</i> or <i>n</i>
D	<i>d</i>	O	<i>0</i> or <i>o</i>
E	<i>E</i>	P	<i>P</i>
F	<i>F</i>	Q	<i>Q</i>
G	<i>G</i>	R	<i>r</i>
H	<i>H</i> or <i>h</i>	S	<i>S</i>
I	<i>I</i>	T	<i>t</i>
J	<i>J</i>	U	<i>U</i>
K	<i>K</i>	V	<i>V</i>
		Y	<i>Y</i>

Table 3.1 Display Characters

...3 DISPLAYS & CONTROLS

3.2 Use of Controls – Fig. 3.2(a) to (f)

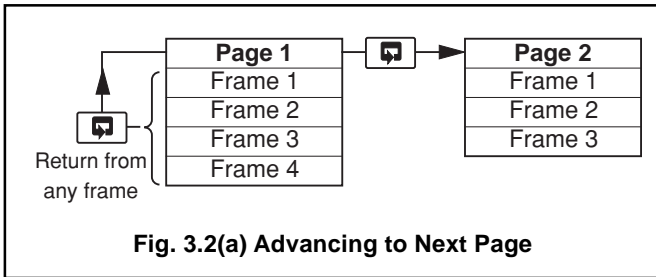

Fig. 3.2(a) Advancing to Next Page

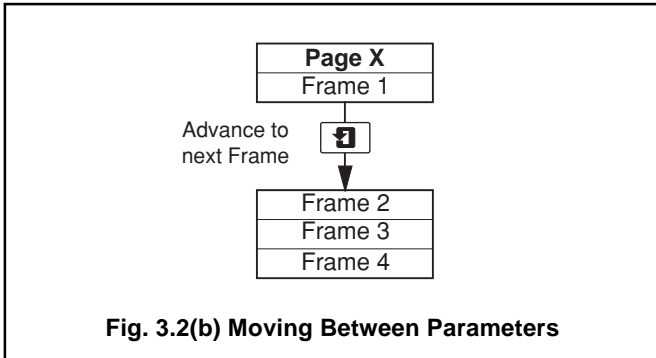

Fig. 3.2(b) Moving Between Parameters

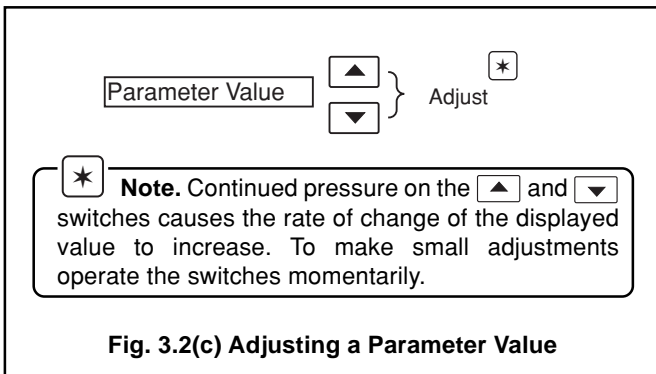

Fig. 3.2(c) Adjusting a Parameter Value

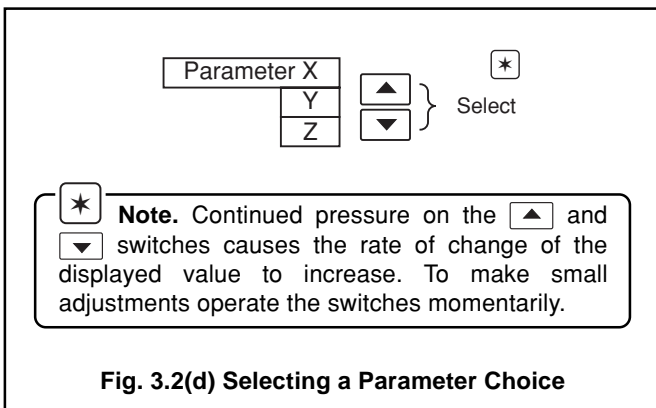

Fig. 3.2(d) Selecting a Parameter Choice

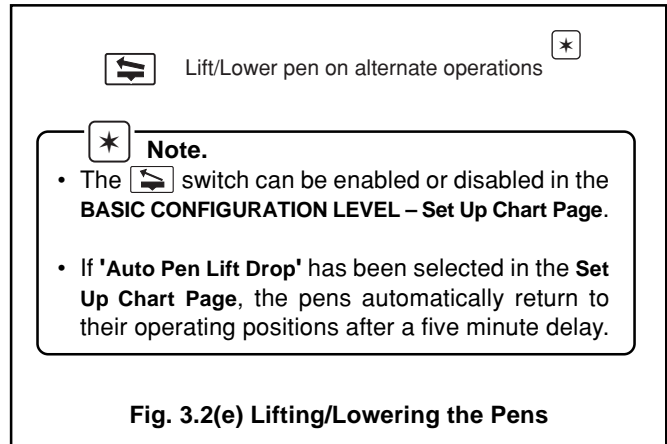

Fig. 3.2(e) Lifting/Lowering the Pens

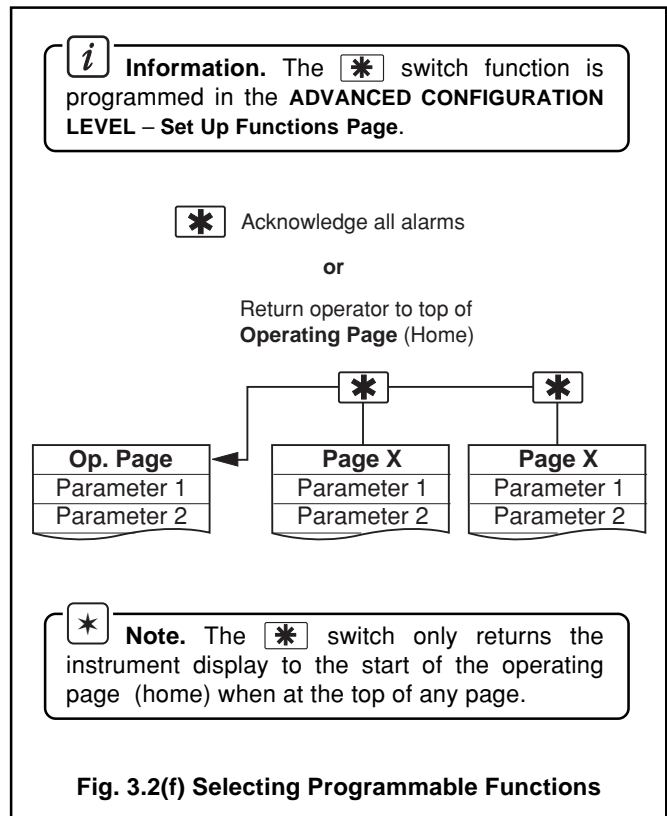

Fig. 3.2(f) Selecting Programmable Functions

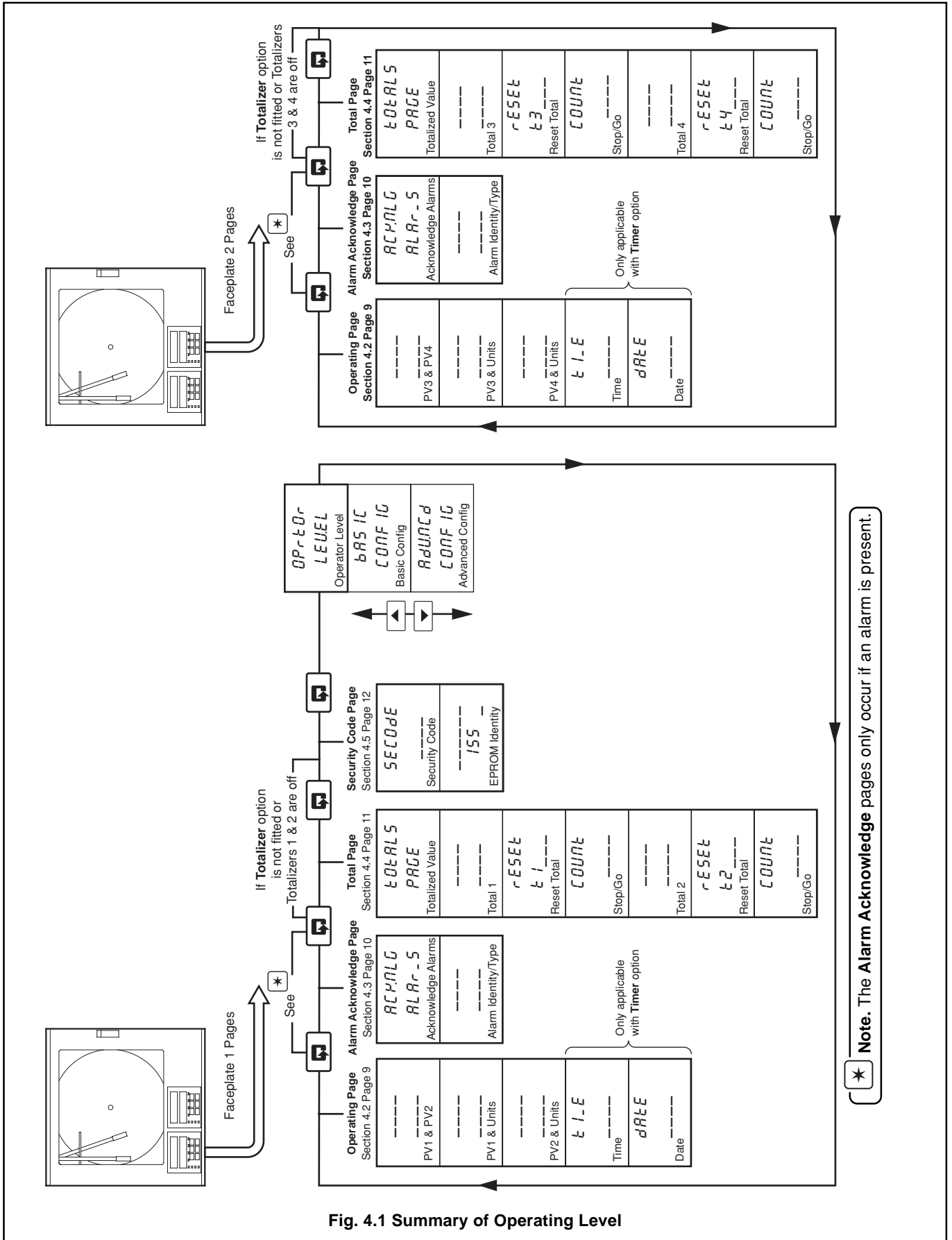

Fig. 4.1 Summary of Operating Level

...4 OPERATION

4.1	Input Error Messages	8
4.2	Operating Page Displays	9
4.3	Alarm Acknowledge Page	10
4.3.1	Alarm Indications	10
4.3.2	Acknowledging Alarms	10
4.3.3	Using the Alarm Acknowledge Page	10
4.4	Totals Page Displays	11
4.5	Access to Configuration Levels	12

The instrument has dedicated **Operating Pages** in the **OPERATOR LEVEL** – see Sections. 4.1 to 4.4. These pages are used for general monitoring of the process measurements and are not affected by the security system which inhibits access to the **PROGRAMMING LEVELS** only – see Section 4.5 on page 12.

4.1 Input Error Messages – Fig. 4.2

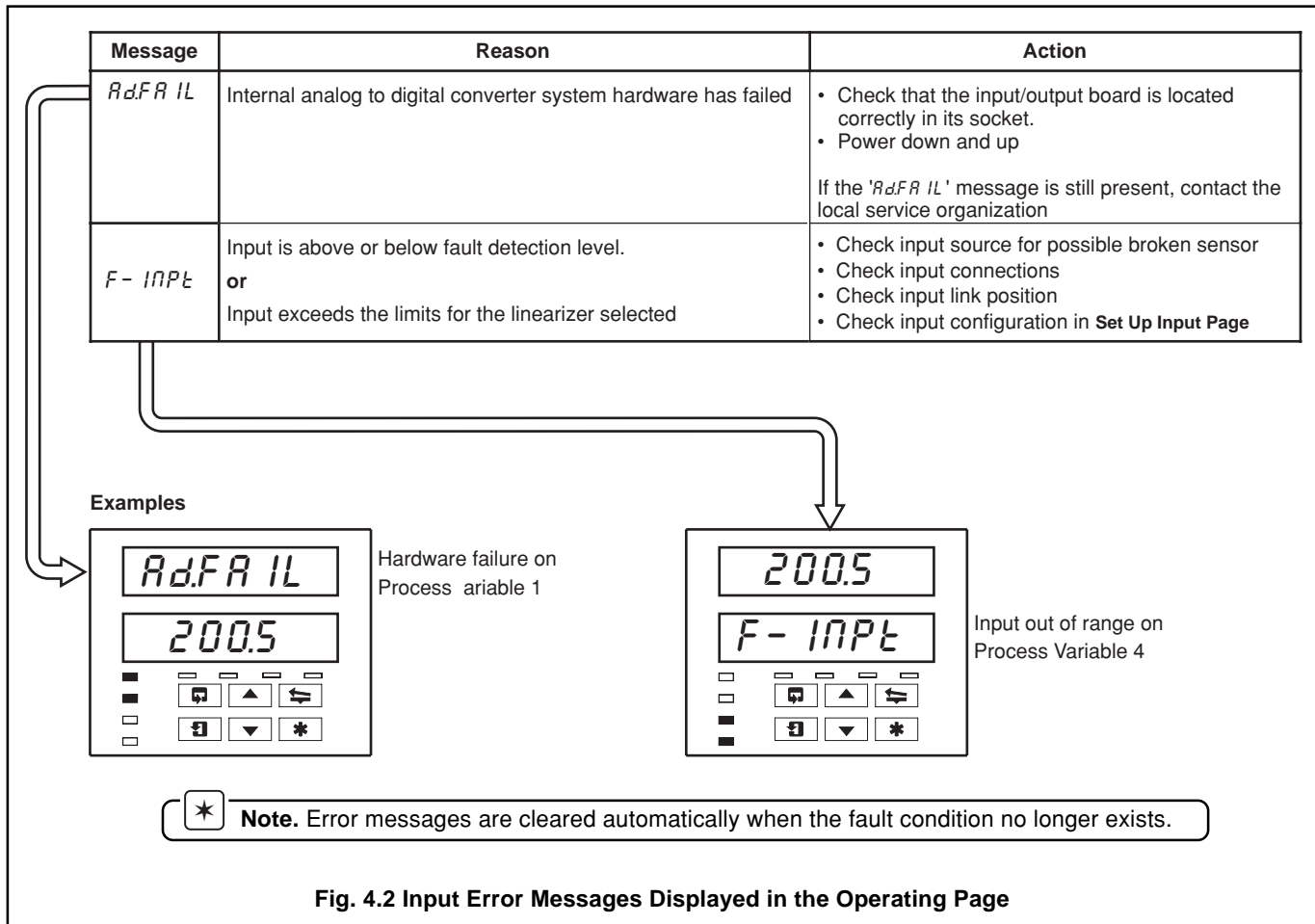

4.2 Operating Page Displays

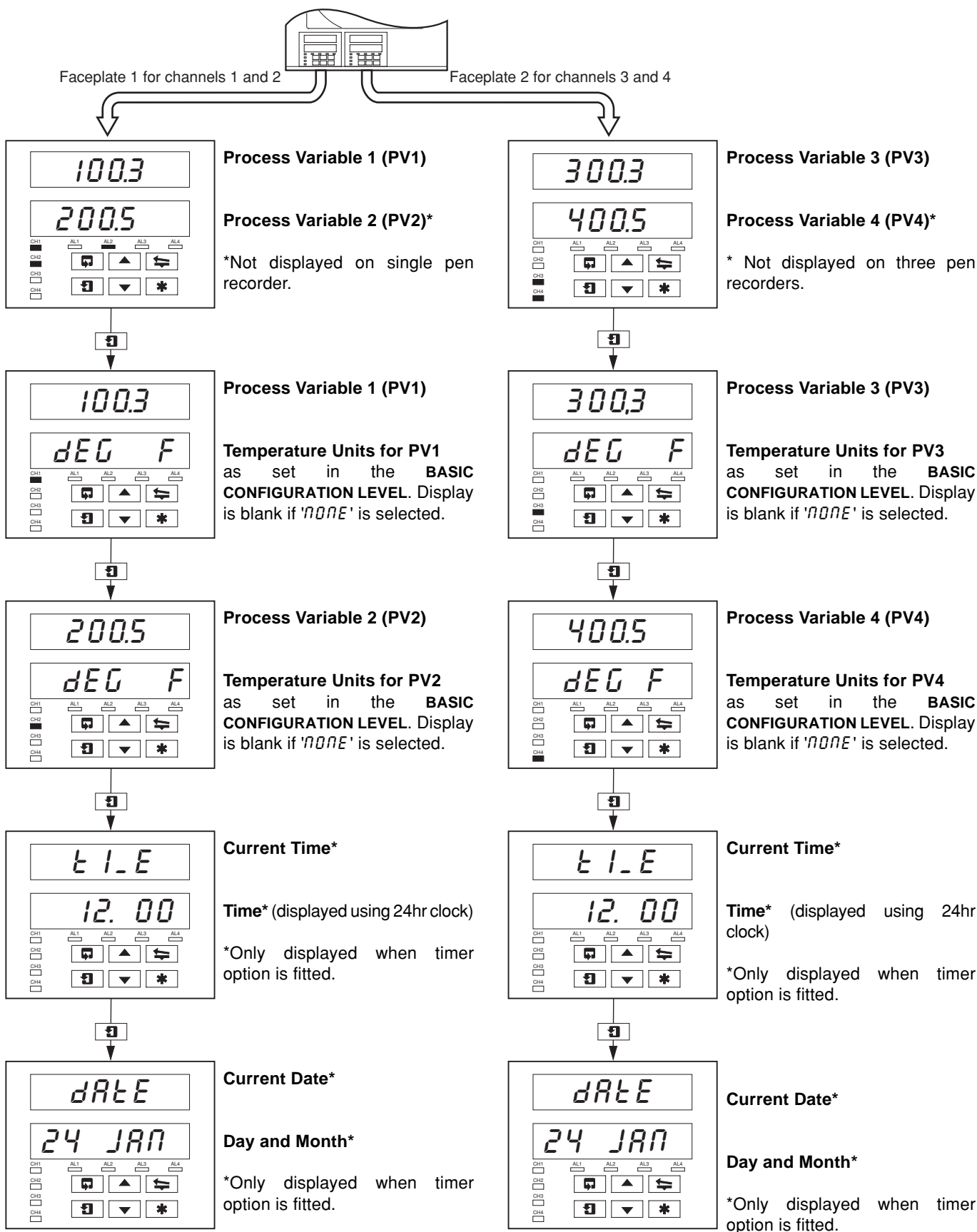

...4 OPERATION

4.3 Alarm Acknowledge Page

4.3.1 Alarm Indications – Fig. 4.3

The definitions for alarm states (on, off or flashing) are detailed in Fig. 4.3.

4.3.2 Acknowledging Alarms

*** Note.** Channel 1 and 2 alarms can only be acknowledged using faceplate 1. Channel 3 and 4 alarms (if applicable) can only be acknowledged using faceplate 2.

Unacknowledged alarms can be acknowledged from the faceplate controls on the front panel in two ways:

In the **OPERATING LEVEL** – by pressing the ***** switch at any frame (providing the switch is programmed for this function – see Section 4.1 in the **Programming Manual**).

In the **Alarm Acknowledge Page** – by pressing the **▲** switch – see Section 4.3.3 following.

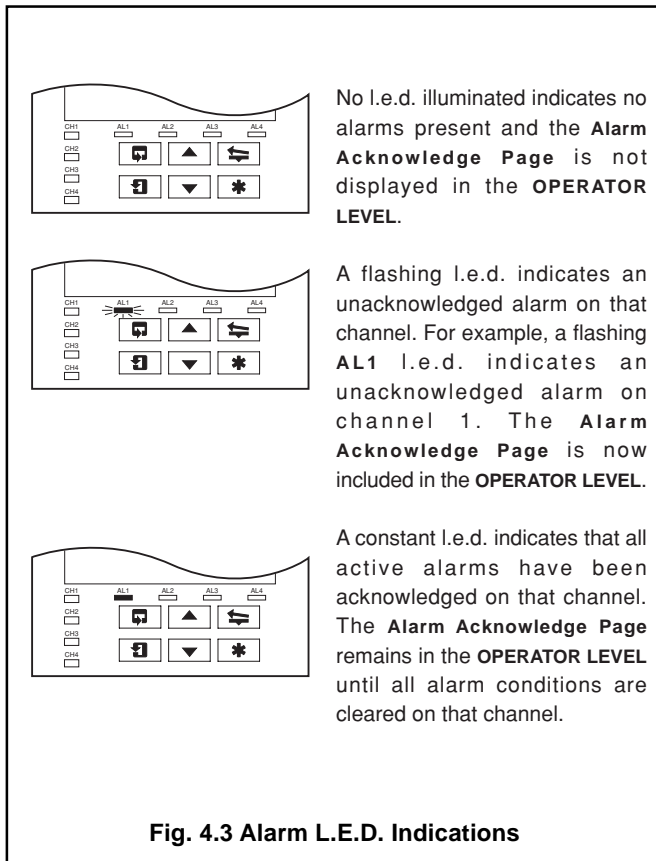

4.3.3 Using the Alarm Acknowledge Page

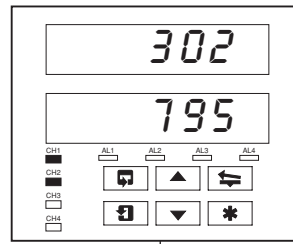

No Alarm Present

No i.e.d. indicators illuminated.

Alarm Activated

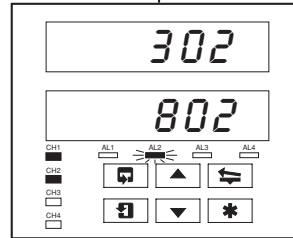

Alarm Present

AL2 i.e.d. indicator flashing, indicating alarm exists on channel 2.

Use **☐** switch to go to top of **Alarm Acknowledge Page**.

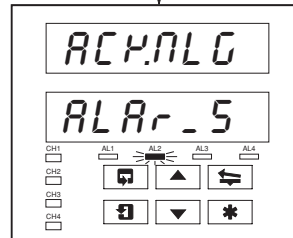

Alarm Acknowledge Page

Use **☐** switch to advance to next frame

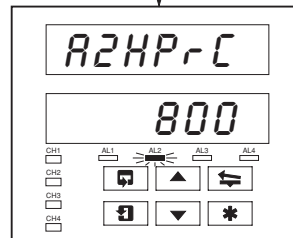

Alarm Identity

Upper display: shows the alarm identity and type.

Lower Display: shows the trip level of the alarm identified in the upper display.

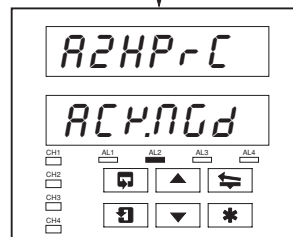

Acknowledge Alarm

Use **▲** switch to acknowledge the alarm (see *****). When the alarm is acknowledged, 'ACK' is displayed and a constant i.e.d. indicates the acknowledged alarm.

If there are more active alarms on channel 2 the i.e.d. continues to flash until all alarms for that channel have been acknowledged.



*** Note.** The ***** switch or a digital input can also be used to acknowledge alarm, if programmed.

4.4 Totals Page Displays

This page is omitted from both faceplates if the **Totalizer Option** is not fitted. The page is also omitted from faceplate 1 if both Totals 1 and 2 are set to *OFF* and from faceplate 2 if both Totals 3 and 4 are set to *OFF* – refer to the **Set Up Totals Page** in the **Advanced Software Options Manual**.

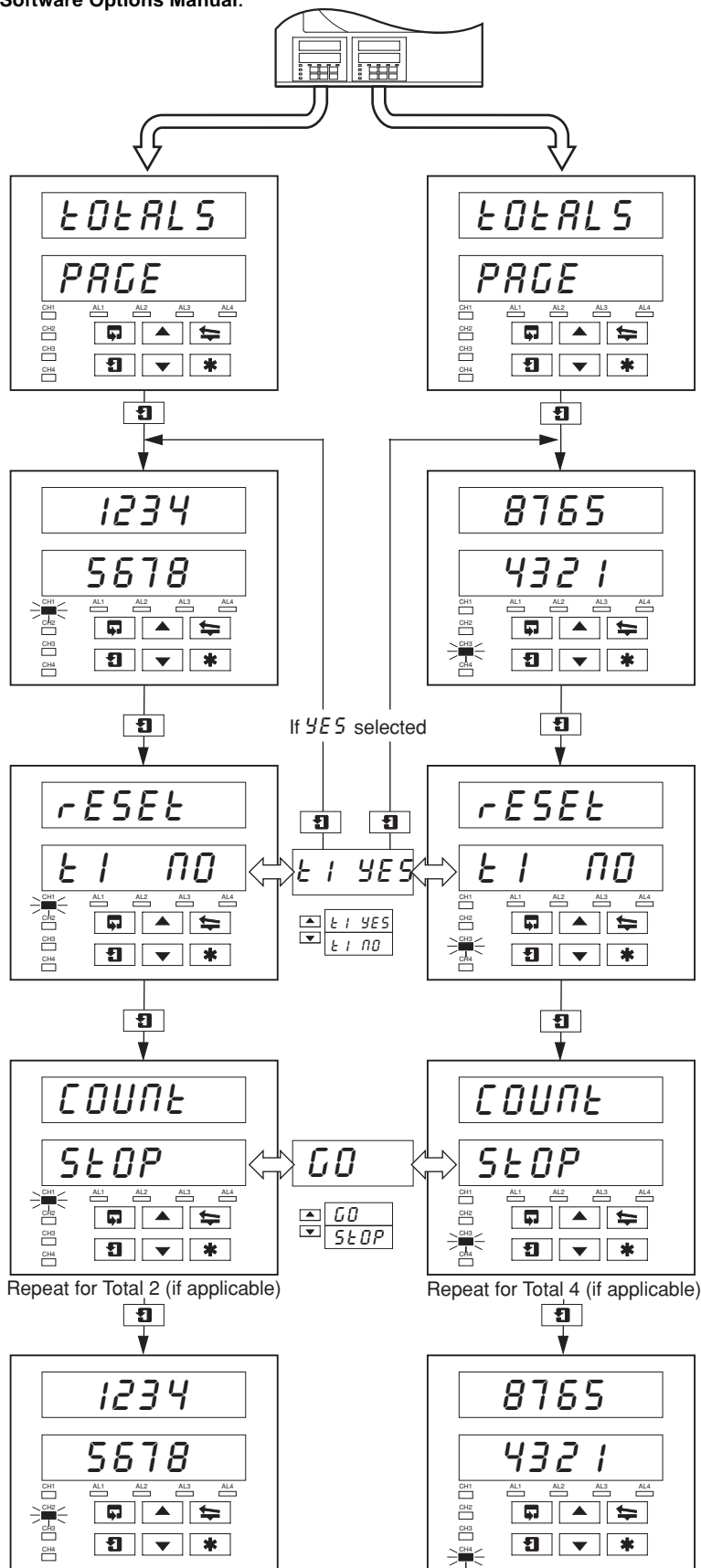

Front Panel (Batch) Flow Total 1 (3)

The batch flow total is calculated from process variable 1 (3). The flow total can be reset if **Reset Enable** in **Set Up Totals Page** is set to *'ENBL - Y'*.

The flashing channel I.e.d. indicates the flow total displayed.

For example, a flashing channel 1 I.e.d. indicates **Flow Total 1** parameters displayed.

Counter Reset

The Front (Batch) Flow Total can be reset to the **Preset Value** in **Set Up Totals Page** if required.

Select *'t1 YES'* to reset the counter (*'t1'* indicates **Flow Total 1**).

Note. If the Counter Reset is disabled in **Set Up Totals Page**, the counter reset frame is omitted.

Counter Stop/Go

Select *'GO'* to start the counter or *'STOP'* to stop it.

Note. If the Counter Stop/Go is disabled in **Set Up Totals Page**, the frame can be viewed but not altered. If a digital signal is assigned to the **Totalizer Stop/Go**, an active digital signal sets the counter to *GO* and the Counter cannot be stopped from the front panel.

Front Panel (Batch) Flow Total 2 (4)

Repeat the above procedure for **Flow Total 2** (4).

Note. The number of totalizers is dependent on the number of pens fitted to the instrument e.g. a 3 pen instrument has 3 totalizers.

...4 OPERATION

4.5 Access to Configuration Levels

A security system is used to prevent tampering with the programmed parameters by utilizing a password giving access to all programming pages – refer to the **Programming Manual**.

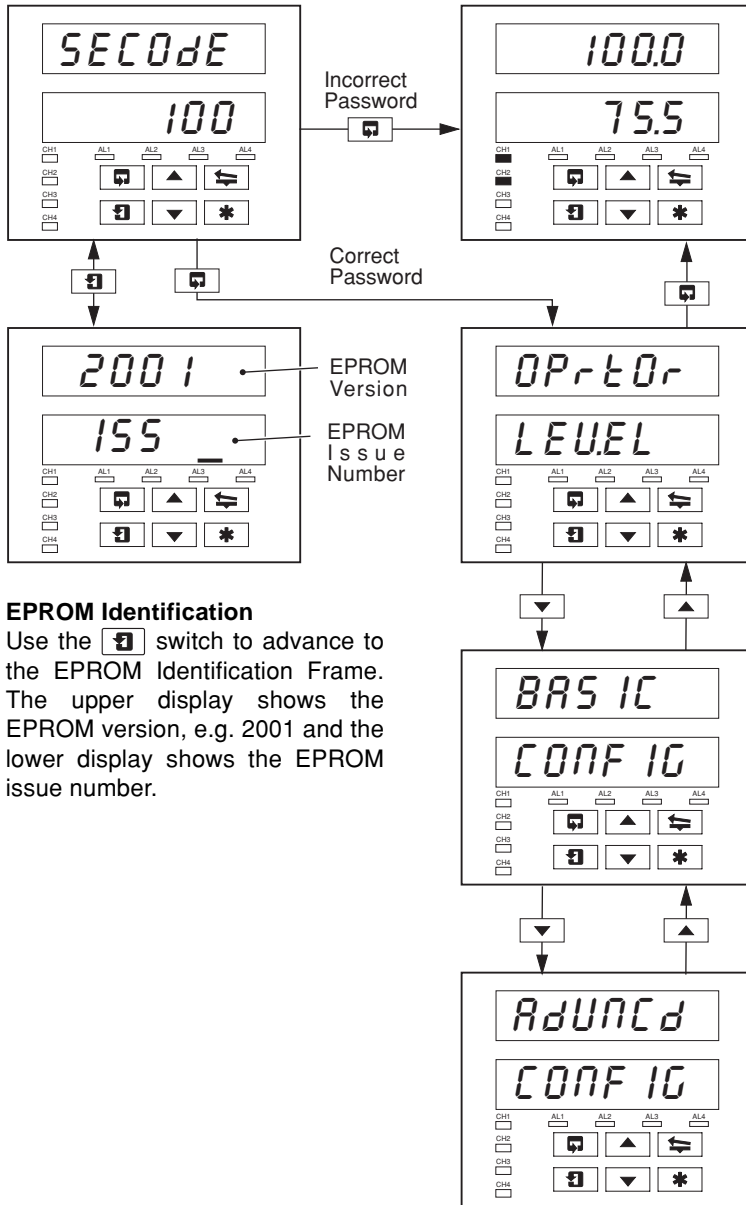

Security Code Page

Set the security code to the correct password using the and switches and use the switch to advance to other programming levels (**OPERATOR**, **BASIC CONFIGURATION** and **ADVANCED CONFIGURATION**).

The password is programmed in the **Access Page** in the **BASIC CONFIGURATION LEVEL**.

EPROM Identification

Use the switch to advance to the EPROM Identification Frame. The upper display shows the EPROM version, e.g. 2001 and the lower display shows the EPROM issue number.

5 SIMPLE FAULT FINDING

Symptom	Possible Cause	Action
Does not power up	a) Internal fuse (if fitted) is blown b) Internal power switch (if fitted) is OFF c) Power supply connections are incorrect	a) Check wiring, rectify fault and replace fuse b) Turn power switch ON c) Check connections
Chart does not appear to move	a) Very slow chart speed selected b) Chart stop function enabled	a) Select required chart speed in Set Up Chart Page b) De-activate source being used to stop chart – see Set Up Chart Page
Pens in recording position but do not drop onto paper	Chart stop function enabled	De-activate source used to stop chart – see Set Up Chart Page
Red pen does not move beyond 94% position on chart	When real time event pen is fitted the red pen cannot go beyond 94% to prevent pens clashing	Use chart range which prevents the need to go beyond 94% of maximum on chart
Pen lift switch on front panel does not work	Pen lift switch is disabled	Enable pen-lift switch in Set Up Chart Page
Pens do not remain lifted when pen lift key is used	Auto pen drop feature is enabled	Disable auto pen drop in Set Up Chart Page if this is not required
Analog inputs are slow to respond	A large filter time has been set	Set digital filter value to give required response in Set Up Inputs Page
Time or date incorrect	Not set for correct local time	Set correct time and date in Set Up Clock Page – refer to Advanced Software Manual
Totalizers cannot be set to STOP or GO	Operator STOP/GO selection is not enabled in the OPERATOR LEVEL	Enable counter STOP/GO in the Set Up Totals Page
Totalizer cannot be set to STOP	Digital signal assigned to the total STOP/GO function is active	De-activate digital signal assigned to total STOP/GO function
External relays connected to relays in instrument fail to de-energize	Arc suppression capacitors are provided across the relay contacts and capacitor leakage current may be sufficient to prevent an external relay from de-energizing	Remove the arc suppression components – IC4 and IC5 on mainboard IC6 and IC7 on standard I/O and analog relay IC3 to IC10 on 4 relay module

6 SPARES LIST

Item	Part No.
Pen Capsules (pack of 3)	
Black	C1900/0119
Blue	C1900/0120
Red	C1900/0121
Green	C1900/0122
Violet*	C1900/0123
Pen Arm Assemblies	
ER/C Type Chart (J or R in Code Number) – Standard Pen	C1900/0076
ER/C Type Chart (J or R in Code Number) – Event Pen	C1900/0078
PX105 and PXR105 Type Chart (K or S in Code Number) – Standard Pen	C1900/0075
PX105 and PXR105 Type Chart (K or S in Code Number) – Event Pen	C1900/0077
Fuses	
24V	B11071 (4A)
115V	B11070 (1A)
230V	B11069 (500mA)

*True time line event option only.

PRODUCTS & CUSTOMER SUPPORT

Products

Automation Systems

- *for the following industries:*
 - Chemical & Pharmaceutical
 - Food & Beverage
 - Manufacturing
 - Metals and Minerals
 - Oil, Gas & Petrochemical
 - Pulp and Paper

Drives and Motors

- *AC and DC Drives, AC and DC Machines, AC motors to 1kV*
- *Drive systems*
- *Force Measurement*
- *Servo Drives*

Controllers & Recorders

- *Single and Multi-loop Controllers*
- *Circular Chart, Strip Chart and Paperless Recorders*
- *Paperless Recorders*
- *Process Indicators*

Flexible Automation

- *Industrial Robots and Robot Systems*

Flow Measurement

- *Electromagnetic Magnetic Flowmeters*
- *Mass Flow Meters*
- *Turbine Flowmeters*
- *Wedge Flow Elements*

Marine Systems & Turbochargers

- *Electrical Systems*
- *Marine Equipment*
- *Offshore Retrofit and Referredishment*

Process Analytics

- *Process Gas Analysis*
- *Systems Integration*

Transmitters

- *Pressure*
- *Temperature*
- *Level*
- *Interface Modules*

Valves, Actuators and Positioners

- *Control Valves*
- *Actuators*
- *Positioners*

Water, Gas & Industrial Analytics Instrumentation

- *pH, conductivity, and dissolved oxygen transmitters and sensors*
- *ammonia, nitrate, phosphate, silica, sodium, chloride, fluoride, dissolved oxygen and hydrazine analyzers.*
- *Zirconia oxygen analyzers, katharometers, hydrogen purity and purge-gas monitors, thermal conductivity.*

Customer Support

ABB Automation provides a comprehensive after sales service via a Worldwide Service Organization. Contact one of the following offices for details on your nearest Service and Repair Centre.

United Kingdom

ABB Automation Ltd
Tel: +44 (0)1480-475-321
Fax: +44 (0)1480-470-787

United States of America

ABB Automation Inc.
Instrumentation Division
Tel: +1 215-674-6000
Fax: +1 215-674-7183

Client Warranty

Prior to installation, the equipment referred to in this manual must be stored in a clean, dry environment, in accordance with the Company's published specification. Periodic checks must be made on the equipment's condition.

In the event of a failure under warranty, the following documentation must be provided as substantiation:

1. A listing evidencing process operation and alarm logs at time of failure.
2. Copies of operating and maintenance records relating to the alleged faulty unit.



The Company's policy is one of continuous product improvement and the right is reserved to modify the information contained herein without notice.

© ABB 2001

Printed in UK (02.01)

ABB Automation Ltd
Howard Road, St. Neots
Cambridgeshire, PE19 8EU
UK
Tel: +44 (0)1480-475-321
Fax: +44 (0)1480-217-948

ABB Automation Inc.
125 E. County Line Road
Warminster, PA 18974
USA
Tel: +1 215-674-6000
Fax: +1 215-674-7183

ABB Automation has Sales & Customer Support
expertise in over 100 countries worldwide

www.abb.com/automation